

# 寸法形状

## ■SV型 (縦型)

型式	貯湯容量 (ℓ)	寸法 (mm)			質量 (kg)
		d	L	H	
WTH-5SV	500	800	1,048	1,648±20	265
WTH-10SV	1,000	900	1,148	2,350±20	340
WTH-15SV	1,500	1,000	1,248	2,564±20	395
WTH-20SV	2,000	1,200	1,448	2,446±20	440
WTH-25SV	2,500	1,200	1,448	2,946±20	510
WTH-30SV	3,000	1,300	1,548	2,986±20	580
WTH-35SV	3,500	1,400	1,648	3,026±20	630
WTH-40SV	4,000	1,500	1,748	2,966±20	695
WTH-45SV	4,500	1,500	1,748	3,266±20	745
WTH-50SV	5,000	1,600	1,848	3,204±20	790
WTH-60SV	6,000	1,600 <td 1,848	3,704±20	875	

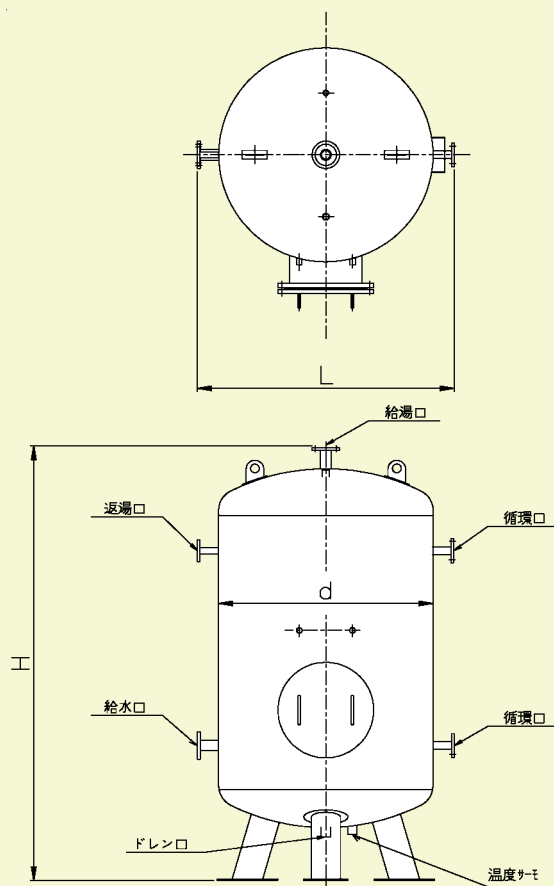

## ■SH型 (横型)

型式	貯湯容量 (ℓ)	寸法 (mm)				質量 (kg)
		d	L	E	H	
WTH-5SH	500	800	1,314±20	474	1,128	250
WTH-10SH	1,000	900	1,930±20	524	1,228	320
WTH-15SH	1,500	900	2,656±20	524	1,228	385
WTH-20SH	2,000	1,000	2,794±20	574	1,328	455
WTH-25SH	2,500	1,000	3,394±20	574	1,328	520
WTH-30SH	3,000	1,100	3,386±20	624	1,428	550
WTH-35SH	3,500	1,200	3,326±20	674	1,528	600
WTH-40SH	4,000	1,200	3,776±20	674	1,528	665
WTH-45SH	4,500	1,200	4,226±20	674	1,528	725
WTH-50SH	5,000	1,300	4,066±20	724	1,628	750
WTH-60SH	6,000	1,400	4,206±20	774	1,728	835
WTH-70SH	7,000	1,500	4,246±20	824	1,828	895
WTH-80SH	8,000	1,600	4,284±20	874	1,928	950
WTH-90SH	9,000	1,600	4,784±20	874	1,928	990
WTH-100SH	10,000	1,600	5,284±20	874	1,928	1,150

